



PRESSURE REGULATORS

GAS BACK PRESSURE

APPLICATION:

Vent lines on oil separators, flow treaters, compressor stations, gas gathering systems.

PRESSURE RANGE:

- Cast Iron: 5 psig to 125 psig
- Ductile Iron: 10 psig to 280 psig
- Steel: 10 psig to 280 psig

CAPACITY:

Refer to Table of Contents.

OPERATION:

The Pilot Assembly and Motor Valve Stem Assembly (Crosshatched) are the only moving units in the regulator. The PILOT PLUG consists of two stainless balls rigidly connected together. The upper seat for the PILOT PLUG is the Motor Valve Diaphragm Pressure inlet (Red to Yellow). The lower seat for the PILOT PLUG is the pressure vent (Yellow to Atmosphere).

The PILOT SPRING in the bonnet loads the upper side of the Pilot Assembly and is opposed on the underside by Upstream Pressure (Red).

Assume the PILOT SPRING is compressed with the ADJUSTING SCREW for a set pressure greater than the Upstream Pressure (Red). The Pilot Assembly is forced downward by the PILOT SPRING. The lower seat for the PILOT PLUG (Yellow to Atmosphere) is closed and the upper seat for the PILOT PLUG (Red to Yellow) is open. This lets full Upstream Pressure (Red) load the motor valve. The area of the MOTOR VALVE DIAPHRAGM is twice the area of the motor valve seat, assuring a positive shut-off.

As the Upstream Pressure (Red) increases to the set pressure, the Pilot Assembly moves upward against the PILOT SPRING to first close the upper seat (Red to Yellow) and open the pressure vent (Yellow to Atmosphere). As the Motor Valve Diaphragm Pressure (Yellow) is decreased, the Upstream Pressure (Red) acting under the motor valve seat, opens the valve. With relief of Upstream Pressure (Red) through the motor valve, the Pilot Assembly assumes a position in which both seats of the PILOT PLUG are closed.

The intermittent bleed pilot, three-way valve action of the PILOT PLUG against its seat adjusts the Motor Valve Diaphragm Pressure (Yellow), repositioning the Motor Valve Stem Assembly to accommodate any rate of flow. The rapid but stable repositioning produces a true throttling action.

- Pilot Assembly
- Motor Valve Stem Assembly
- Upstream Pressure
- Motor Valve Diaphragm Pressure

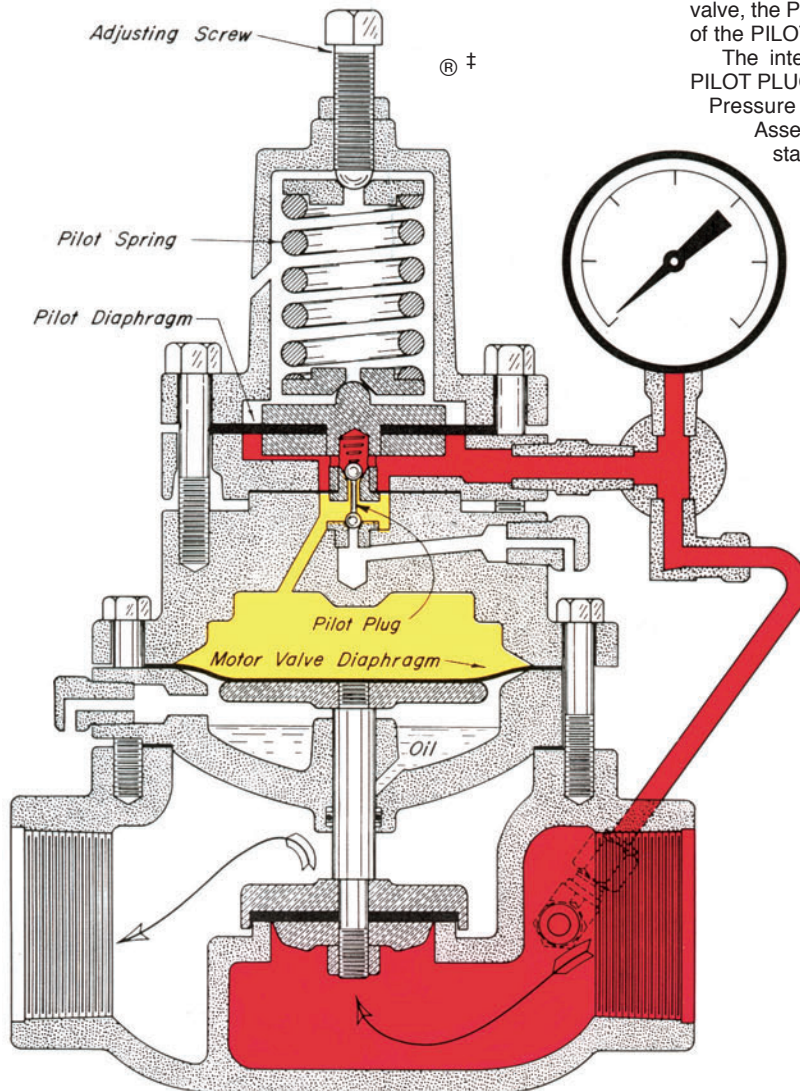



PRESSURE REGULATORS

GAS BACK PRESSURE DUCTILE IRON

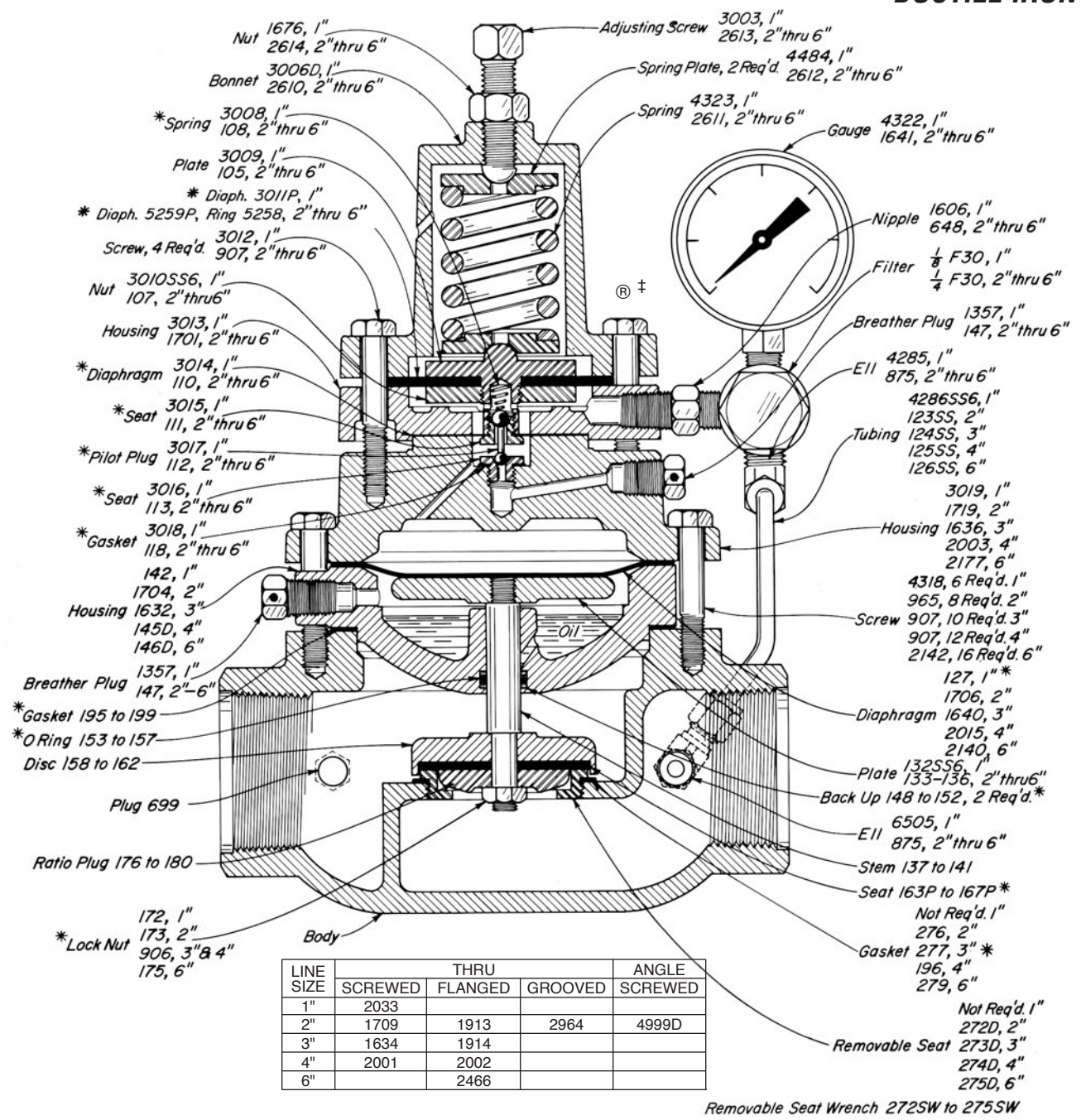

THRU VALVES AVAILABLE:

CAT. NO.	SIZE TYPE	REG. NO	OPER. PRES.	MAX W.P.	KIT
AKB	1" SCR.D.	130 SGT BP-D	300	300	RRU
AAR	2" SCR.D.	230 SGT BP-D	300	300	RDG
AAS	2" FLGD.	218 FGT BP-D	250	250	RDG
AAQ	2" GRVD.	230 GGT BP-D	300	300	RDG
AAT	3" SCR.D.	330 SGT BP-D	300	300	RDH
AAU	3" FLGD.	318 FGT BP-D	250	250	RDH
AAW	4" SCR.D.	430 SGT BP-D	300	300	RDI
AAX	4" FLGD.	418 FGT BP-D	250	250	RDI
AAZ	6" FLGD.	618 FGT BP-D	250	250	RDJ

ANGLE VALVES AVAILABLE:

CAT. NO.	SIZE TYPE	REG. NO	OPER. PRES.	MAX W.P.	KIT
ASR	2" SCR.D.	230 SGA BP-D	300	300	RDG

Dimensions, refer to Table of Contents.

*These parts are recommended spare parts and are stocked as repair kits.

The numbers of a series assigned to a part indicate different line sizes. For example: Seat 163P-1", 164P-2", 165P-3", 166P-4", 167P-6".

‡Configuration of the Back Pressure valve is a trademark of Kimray, Inc.



GAS CAPACITY CHARTS

200, 285, 300 & 500 psig Maximum W.P. Valves

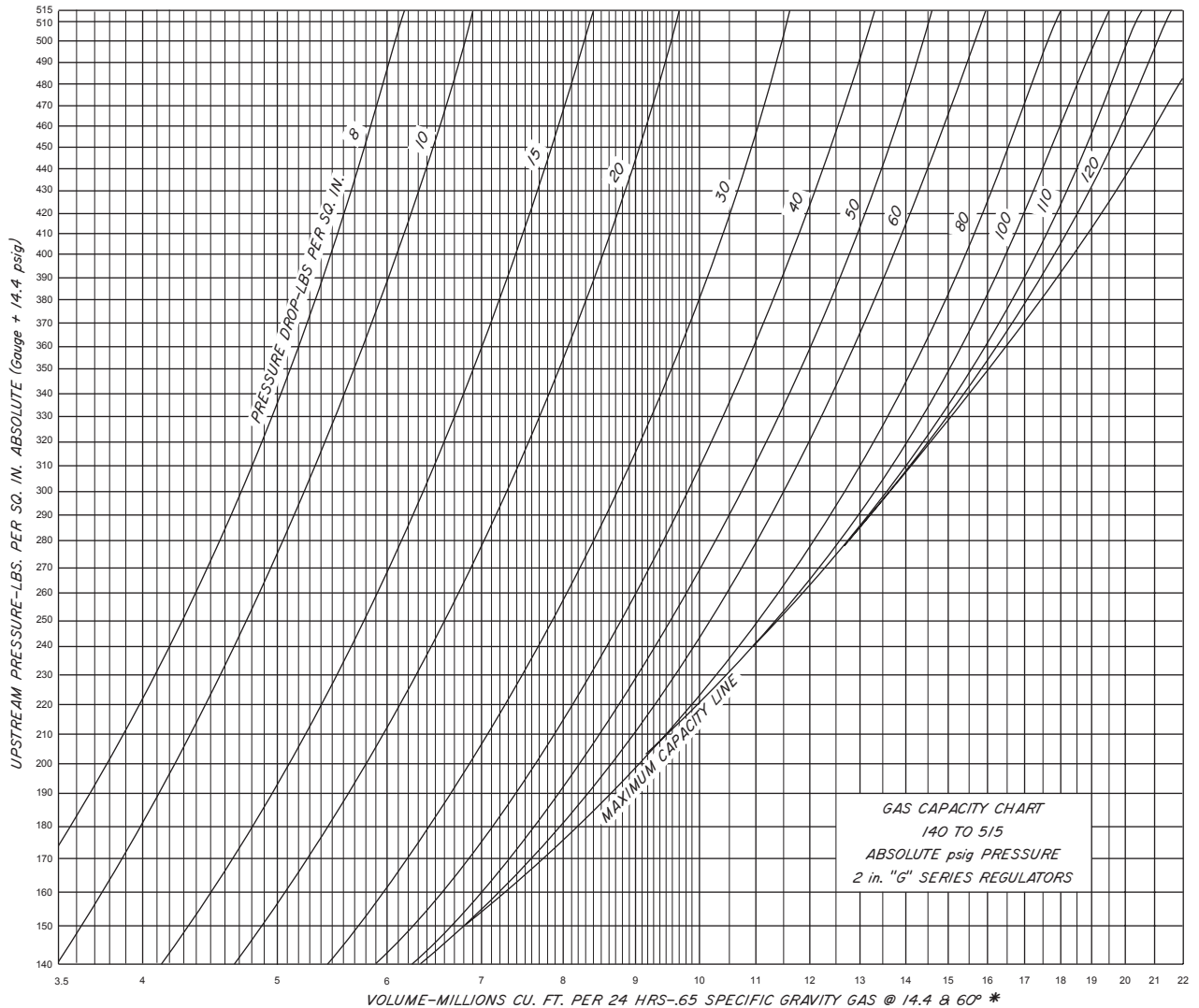

Gas capacities are based on pressure taken immediately upstream and downstream from the regulator in a wide open position.

Critical flow exists across a valve or orifice when the downstream absolute pressure is approximately half of the upstream absolute pressure. Any decrease in downstream pressure will not increase the flow through the valve. Critical flow conditions on the charts are represented by the MAXIMUM CAPACITY LINE.

HOW TO USE CHARTS: Locate UPSTREAM PRESSURE at left of chart. Follow horizontally across to PRESSURE DROP (upstream minus downstream pressure). Read VOLUME directly below. If the horizontal projection of the upstream pressure does not intersect the given pressure drop, flow is critical. In this case project UPSTREAM PRESSURE horizontally to the MAXIMUM CAPACITY LINE and read VOLUME directly below.

*For gravity correction multiply above capacities by $\sqrt{\frac{.65}{G}}$ where G equals specific gravity of gas.

GAS CAPACITY CHARTS

220, 285, & 300 psig Maximum W.P. Valves

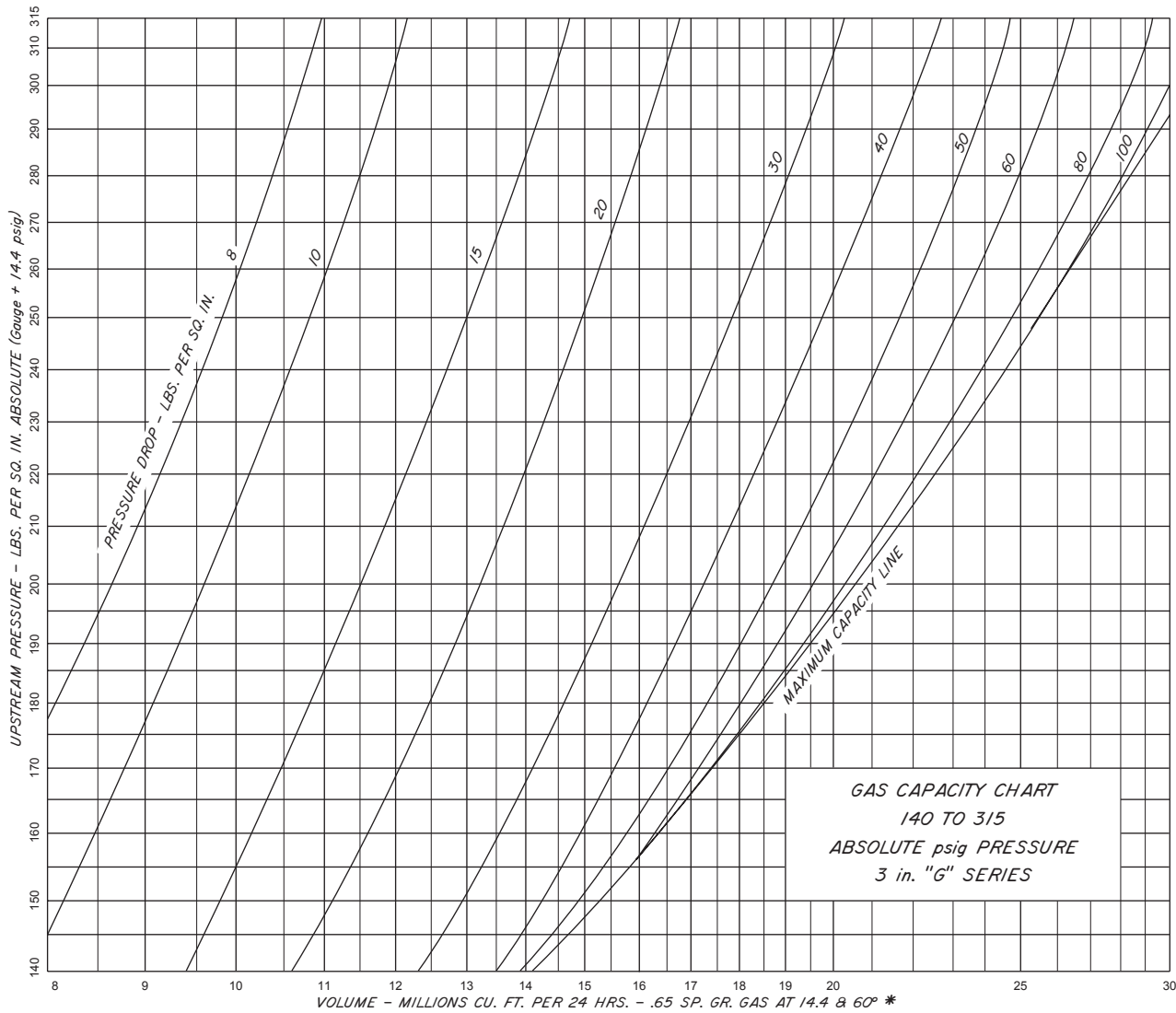

Gas capacities are based on pressure taken immediately upstream and downstream from the regulator in a wide open position.

Critical flow exists across a valve or orifice when the downstream absolute pressure is approximately half of the upstream absolute pressure. Any decrease in downstream pressure will not increase the flow through the valve. Critical flow conditions on the charts are represented by the MAXIMUM CAPACITY LINE.

HOW TO USE CHARTS: Locate UPSTREAM PRESSURE at left of chart. Follow horizontally across to PRESSURE DROP (upstream minus downstream pressure). Read VOLUME directly below. If the horizontal projection of the upstream pressure does not intersect the given pressure drop, flow is critical. In this case project UPSTREAM PRESSURE horizontally to the MAXIMUM CAPACITY LINE and read VOLUME directly below.

*For gravity correction multiply above capacities by $\sqrt{\frac{.65}{G}}$ where G equals specific gravity of gas.



GAS CAPACITY CHARTS

220, 285, & 300 psig Maximum W.P. Valves

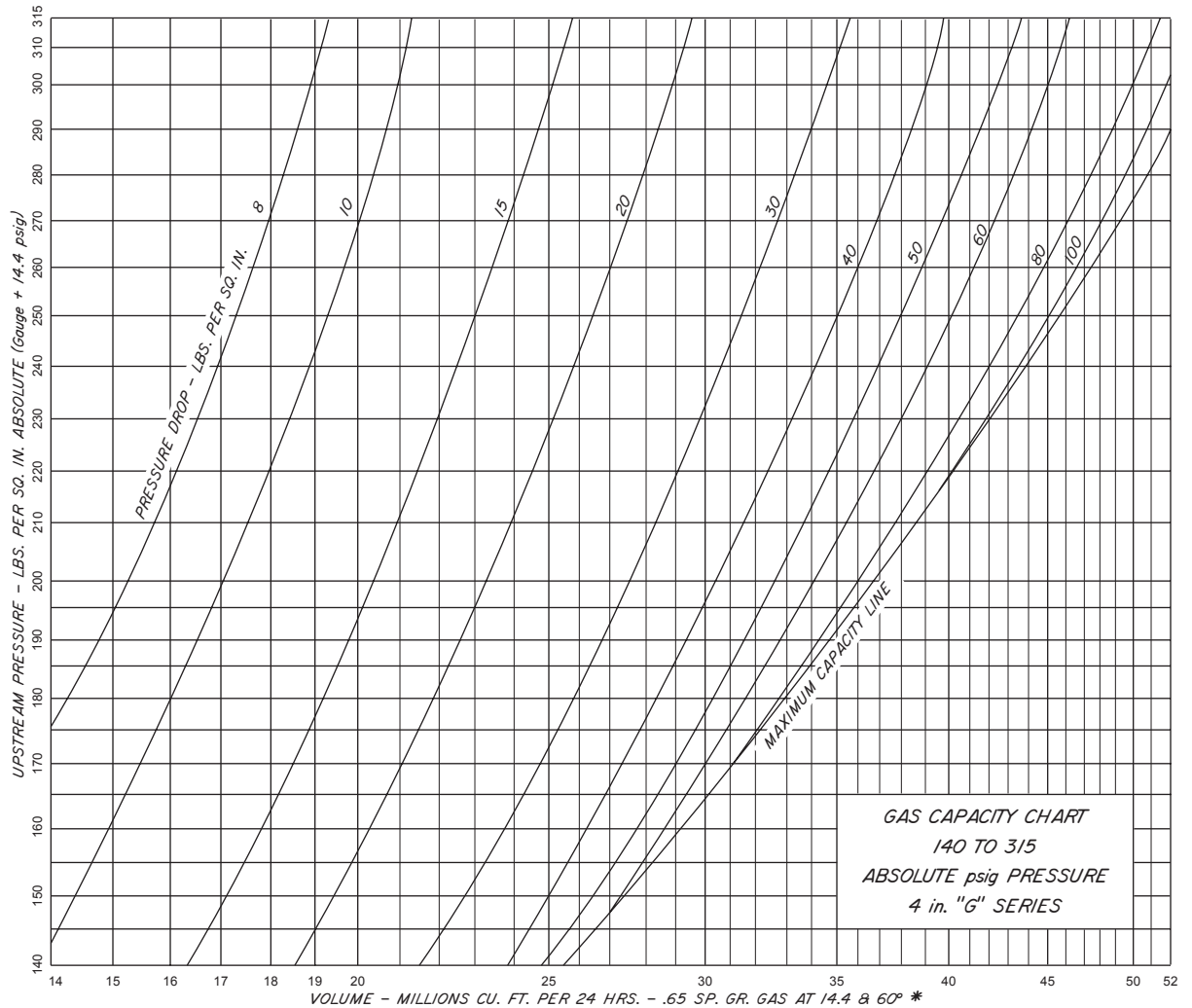

Gas capacities are based on pressure taken immediately upstream and downstream from the regulator in a wide open position.

Critical flow exists across a valve or orifice when the downstream absolute pressure is approximately half of the upstream absolute pressure. Any decrease in downstream pressure will not increase the flow through the valve. Critical flow conditions on the charts are represented by the MAXIMUM CAPACITY LINE.

HOW TO USE CHARTS: Locate UPSTREAM PRESSURE as left of chart. Follow horizontally across to PRESSURE DROP (upstream minus downstream pressure). Read VOLUME directly below. If the horizontal projection of the upstream pressure does not intersect the given pressure drop, flow is critical. In this case project UPSTREAM PRESSURE horizontally to the MAXIMUM CAPACITY LINE and read VOLUME directly below.

*For gravity correction multiply above capacities by $\sqrt{\frac{.65}{G}}$ where G equals specific gravity of gas.



LIQUID CAPACITY CHARTS

300 psig Maximum W.P. Valves

CAPACITY-Bbls. Water/Day, Steady Flow

PRESSURE DROP ACROSS VALVE PSIG	VALVE SIZE - INCHES			
	1	2	3	4
1	745	1,760	3,350	7,800
2	1,060	2,500	4,900	11,000
3	1,300	3,050	6,100	13,500
4	1,500	3,500	7,000	15,600
5	1,700	3,900	7,800	17,500
10	2,300	5,600	11,000	24,700
15	2,900	6,800	13,500	30,200
20	3,300	7,900	15,600	34,900
30	4,100	9,600	19,200	42,700
40	4,700	11,100	22,100	49,300
50	5,300	12,400	24,800	55,200
60	5,800	13,600	27,100	60,500
70	6,200	14,700	29,300	65,400
80	6,700	15,700	31,300	69,800
100	7,500	17,600	33,500	78,200
125	8,400	19,700	39,200	87,500
150	9,300	21,500	40,750	93,000
200	10,750	25,000	47,000	108,000
250	12,100	28,000	52,000	120,000
300	13,300	30,900	57,250	130,000

For gravity correction, multiply the above figures by $\sqrt{\frac{1}{G}}$
 Where "G" is the specific gravity of the flowing liquid.

GAS SERIES REGULATOR



DIMENSIONS

FOR: BACK PRESSURE
UPSTREAM DIFFERENTIAL PRESSURE
PRESSURE REDUCING-BALANCED
PRESSURE REDUCING VACUUM

PRESSURE DIFFERENTIAL
PRESSURE REDUCING
BACK PRESSURE VACUUM
LIQUID BACK PRESSURE

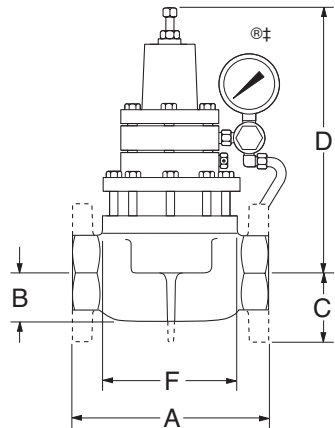

CAST IRON OR DUCTILE

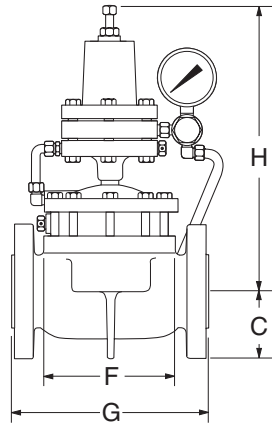

STEEL

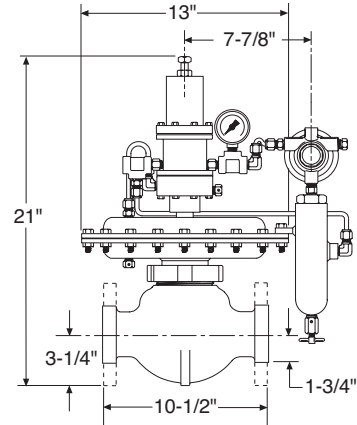

250 S/FGT-BP-S

FOR: LOW PRESSURE BACK PRESSURE
OUNCES BACK PRESSURE TO VACUUM
OUNCES PRESSURE REDUCING
OUNCES PRESSURE REDUCING VACUUM
VACUUM BACK PRESSURE TO VACUUM

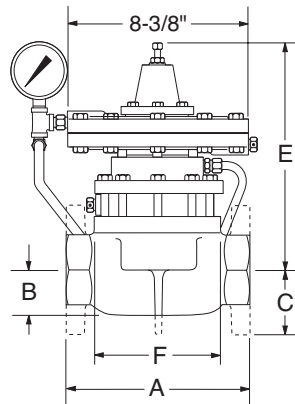

CAST IRON OR DUCTILE

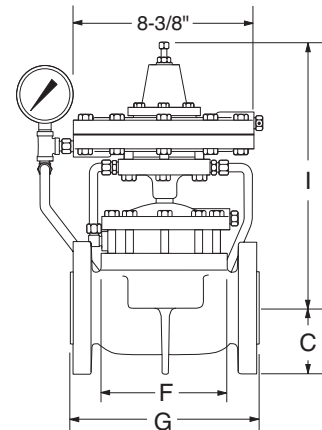

STEEL

LINE SIZE	BODY STYLE	A	B	C	D*	E	F	G	H*	I
1 "	SCRD	4 3/8"	1 1/8"		7 1/2"	11 5/8"	3 1/4"			
2 "	SCRD	8 1/2"	2 1/8"		11 1/2"	10 1/2"	6 1/2"			
	FLGD	9"		3	11 1/2"	10 1/2"	6 1/2"	9 1/8"	14 1/2"	14"
	GRVD	8 3/4"	2 1/8"		11 1/2"	10 1/2"	6 1/2"			
250 S/FGT	SCRD			1 3/4"				10 1/2"		
	FLGD			3 1/4"				10 1/2"		
3 "	SCRD	12"	3 1/16"		13"	12"	8 1/2"			
	FLGD	12 3/16"		3 3/4"	13"	12"	8 1/2"	12 5/16"	16 1/2"	15 1/2"
4 "	SCRD	15"	4"		14 1/2"	13 3/16"	10 1/2"			
	FLGD	15 1/8"		4 1/2"	14 1/2"	13 3/16"	10 1/2"	15"	18 1/2"	16 11/16"
6 "	FLGD	22 1/8"		5 1/2"	17"	14 7/8"	16"	22"	20 1/2"	18 3/8"

FLANGE DIMENSIONS ARE ANSI 125/150 STANDARD. *Add 7/8" to PRB and USDP Regulators for this dimension.