

APPLICATIONS:

Used to produce a pneumatic output signal when the monitored pressure falls below the set pressure.

Used in conjunction with Kimray MT series valve for regulation of pressure where the pressure to the valve varies more than 2:1 and regulated pressure must be kept to less than 2 psig change.

OPERATION:

The 30 PG PRDA-D Pilot can be considered to be an indirect multiplier. Each 1 psig change in Controlled Pressure results in a change in Output pressure of 8 psig.

SUPPLY PRESSURE:

5 to 300 psig when used with MT series valve.

PRESSURE RANGE:

5 psig to 280 psig

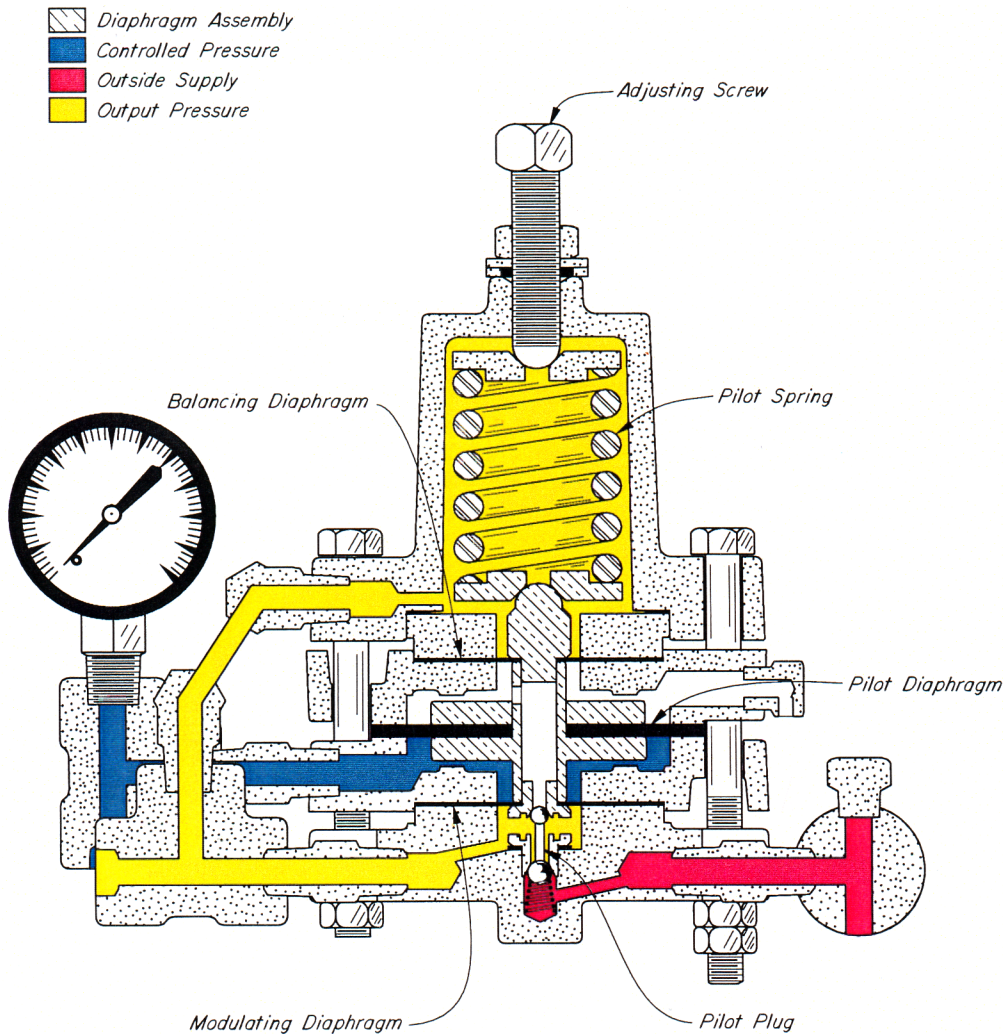

30 PG PRB-D
 DUCTILE
 300 lbs. W.P.

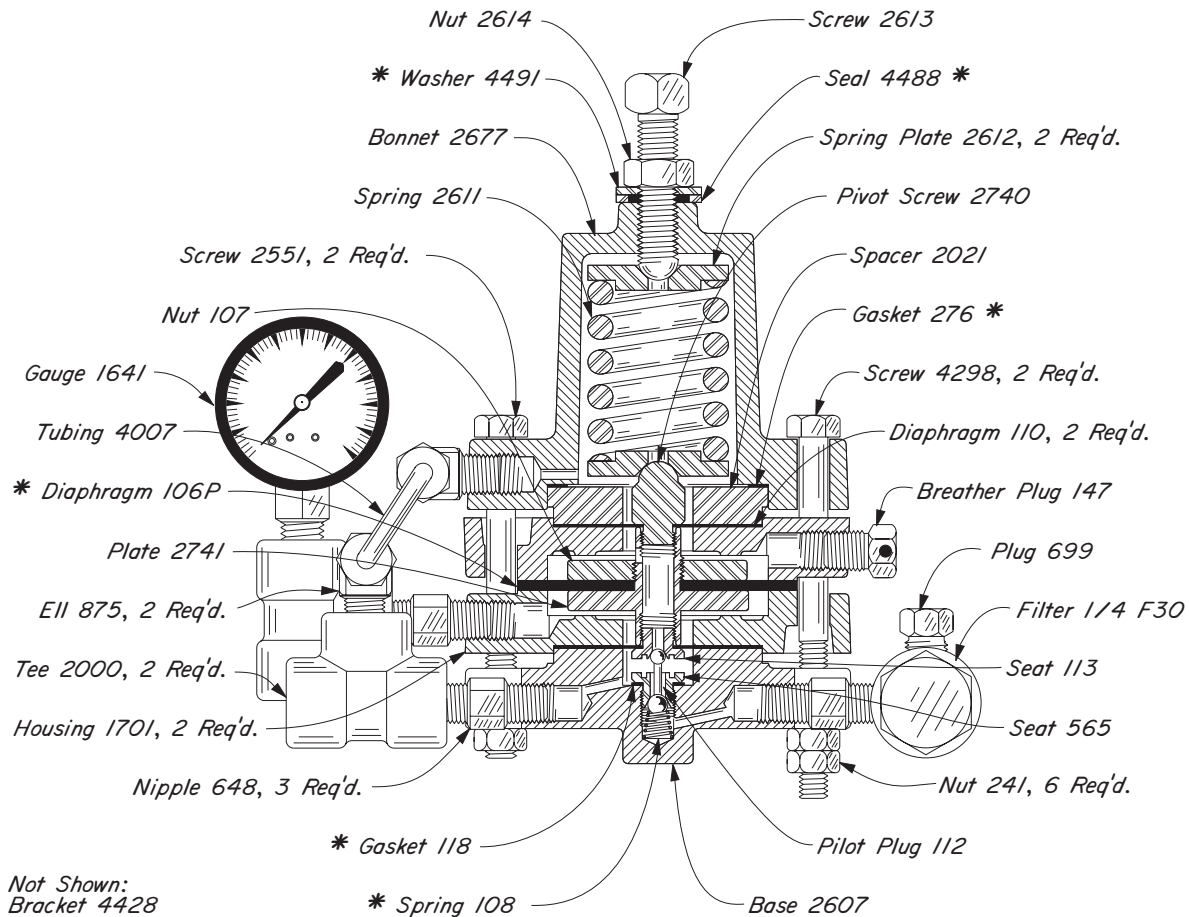

PILOTS AVAILABLE:

CAT. NO.	PILOTS	DES. PRESS.	OPER. PRESS.
AHM	30 PG PDDA-S	300	280

*These are recommended spare parts and are stocked as repair kits. To order repair kit, specify: "30 PG PRB-D Repair Kit, RSR"