

APPLICATIONS:

Salt water lowers are used in corrosive conditions to extend the packing gland life of the stem seals and to aid in seal removal and replacement.

**SALT WATER LOWER HOUSING
CAST IRON
125 lbs. W.P.**

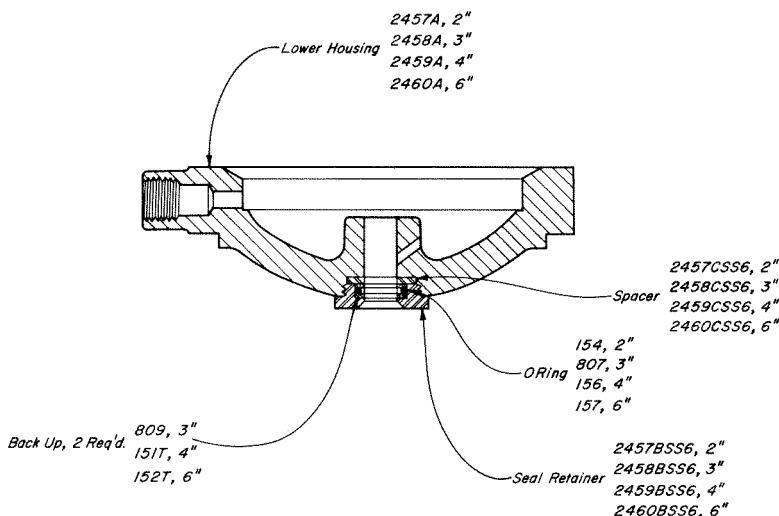

**SALT WATER LOWER HOUSING
DUCTILE IRON
125-300 lbs. W.P.**

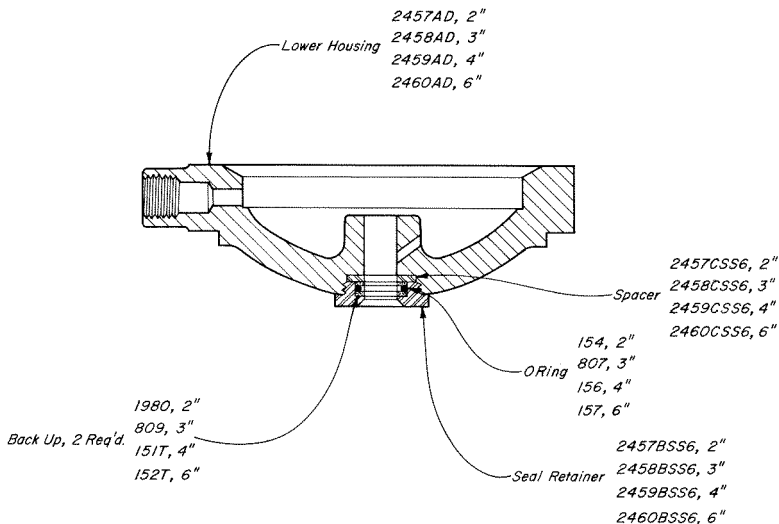

**SALT WATER LOWER HOUSING ASSEMBLIES
AVAILABLE: CAST IRON**

PART NO.	LINE SIZE	DESCRIPTION
2457	2"	Lower Housing Assembly
2458	3"	Lower Housing Assembly
2459	4"	Lower Housing Assembly
2460	6"	Lower Housing Assembly

**SALT WATER LOWER HOUSING ASSEMBLIES
AVAILABLE: DUCTILE IRON**

PART NO.	LINE SIZE	DESCRIPTION
2457D	2"	Lower Housing Assembly
2458D	3"	Lower Housing Assembly
2459D	4"	Lower Housing Assembly
2460D	6"	Lower Housing Assembly